



Low Profile Rotatable XLR Male

APPLICATION & ASSEMBLY INSTRUCTION

Item Code: **LX3M**

1. PACKAGE LIST

ROXTONE



Color Rings x 2 (BK, OG)

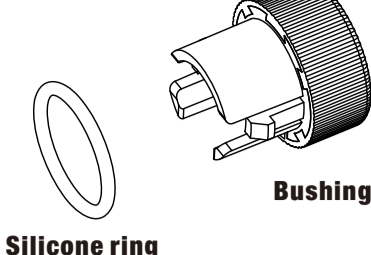

Silicone ring

Bushing



Connector Shell

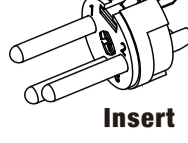

Insert



Mini Zip-Tie x 2



heat-shrink tube x 2

2. ASSEMBLY INSTRUCTION

STEP 1 Remove about 15mm of the cable jacket.



STEP 2 Fray and twist shielding tight. Remove about 4mm of the leads jacket at the end.

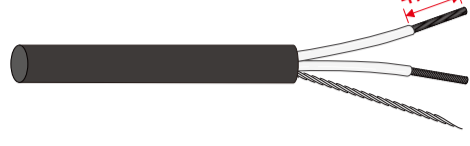

STEP 3 Put heat-shrink tube over the shielding, leaving the 4mm tip exposed.



STEP 4 Solder the leads into the insert solder cups, heat the shrink tube. Install the mini-zip tie 4mm from jacket section and tighten, cut the excess part.

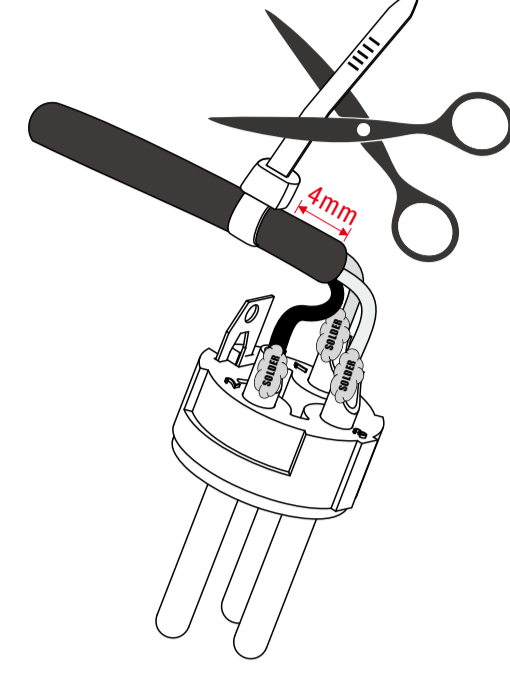

STEP 5 Depending on different application scenarios, the product can be divided into two assembly modes **A** and **B** (as shown in the following figure) according to the orientation of the cable exit.

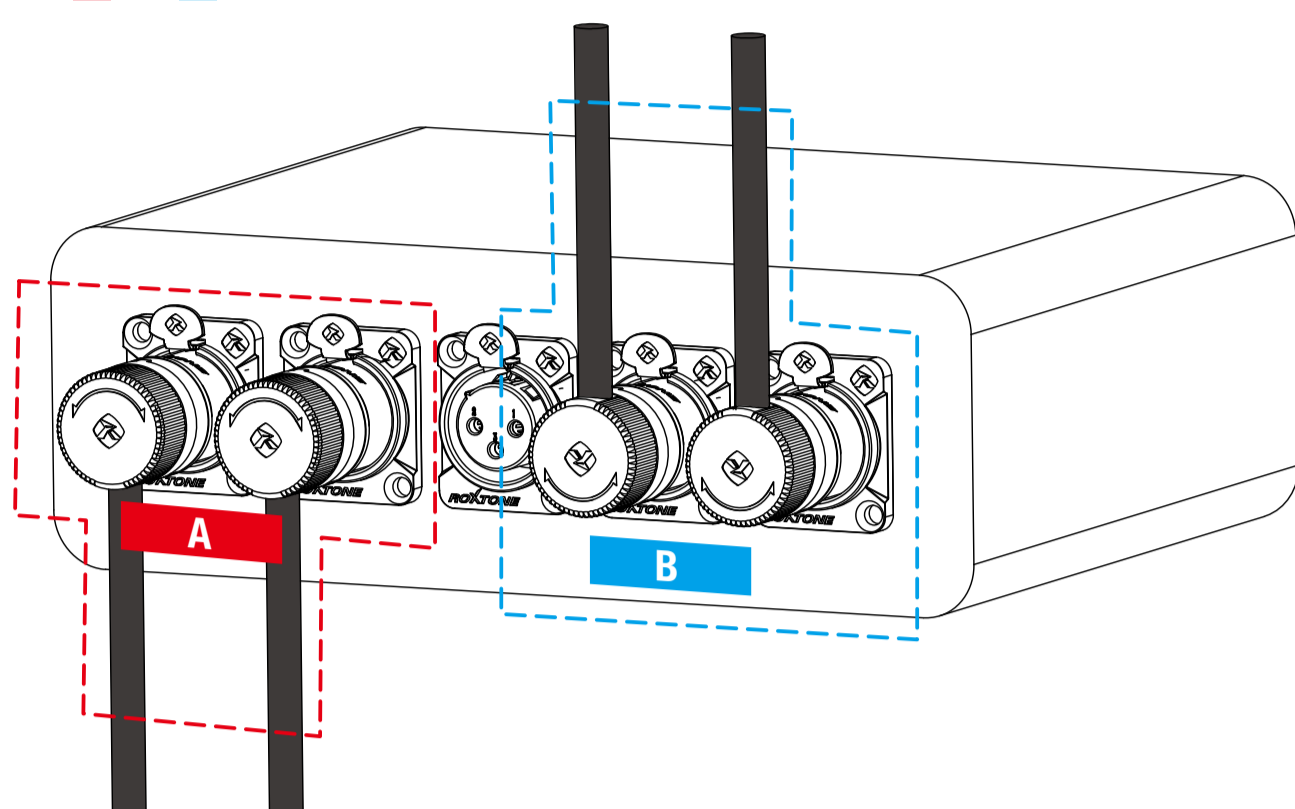

A

B

A-1

B-1

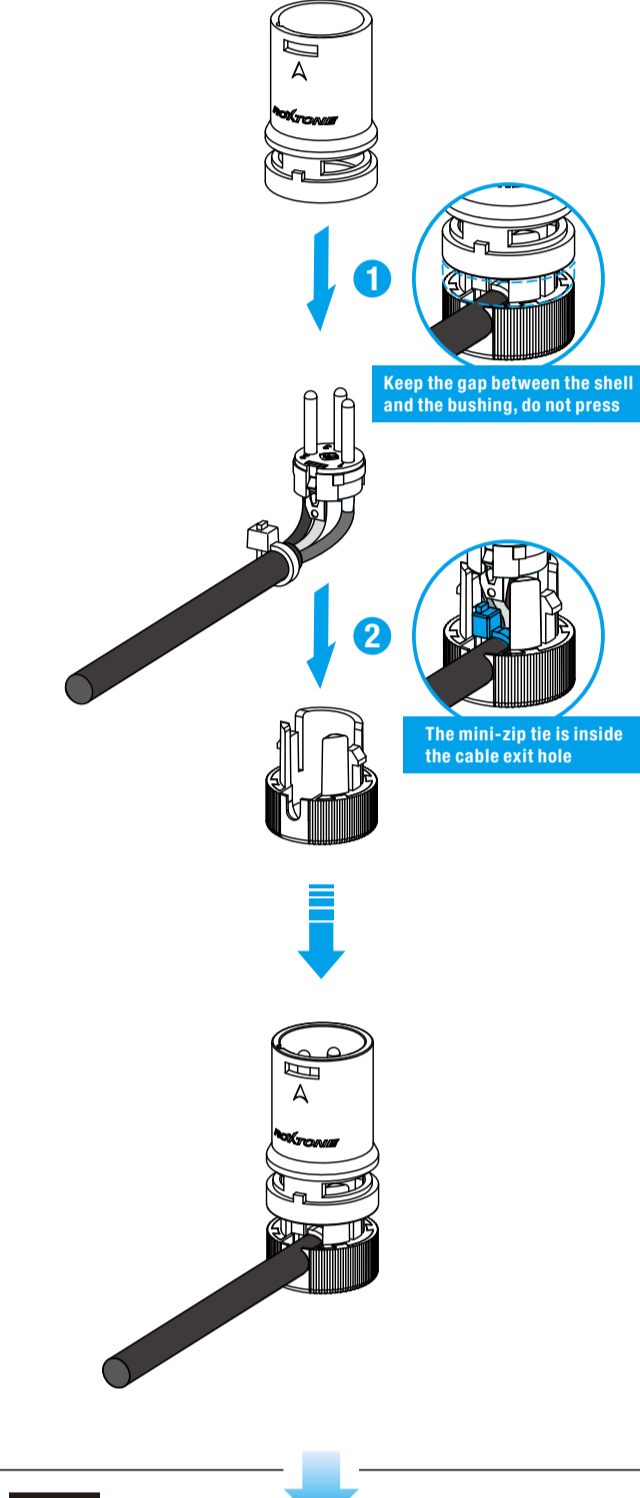
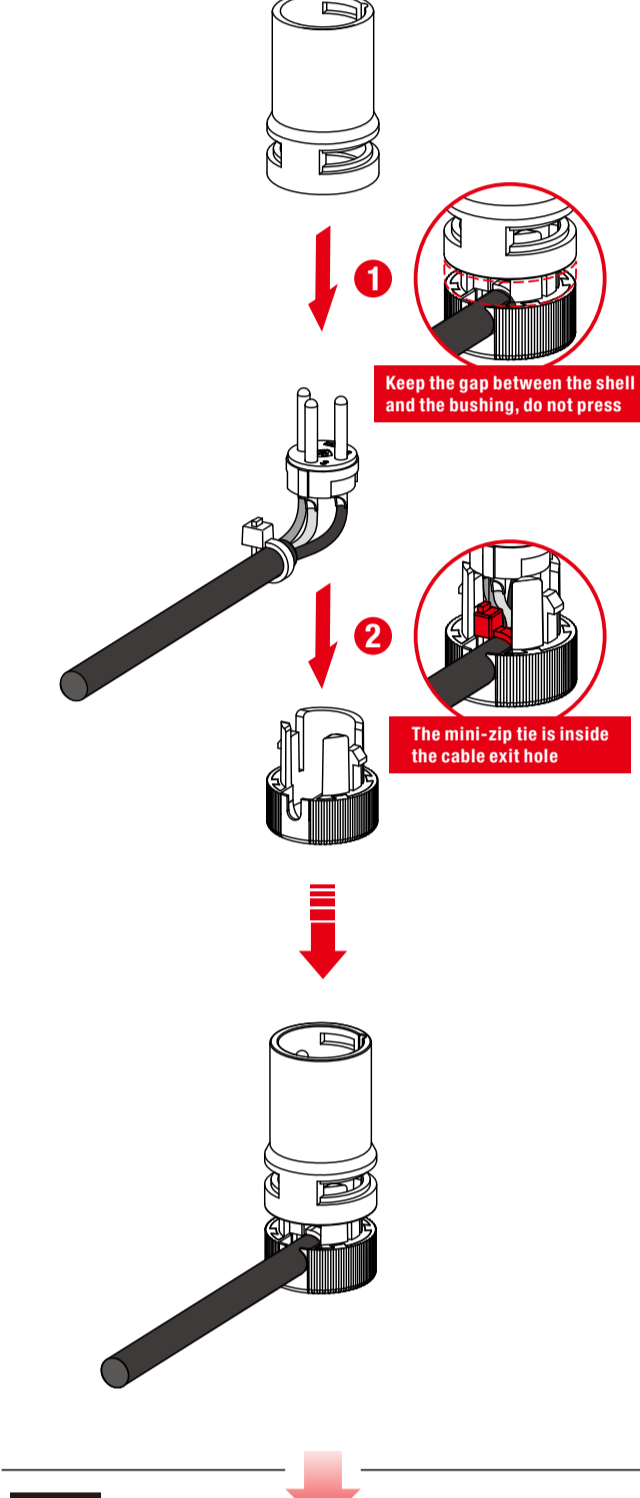

A-2

B-2

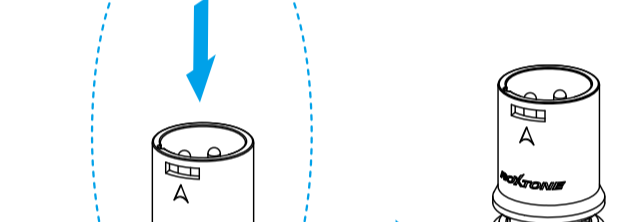
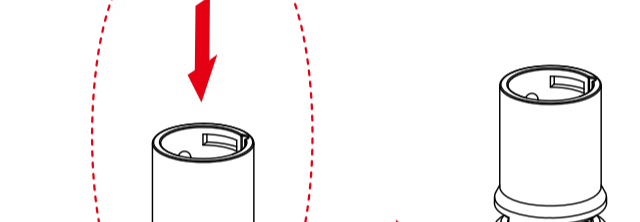

A-3

B-3

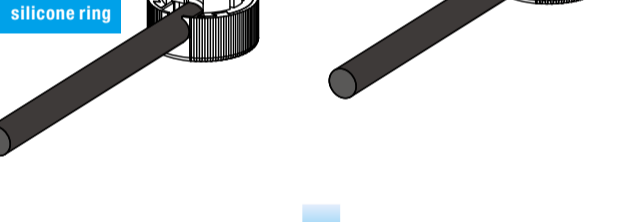
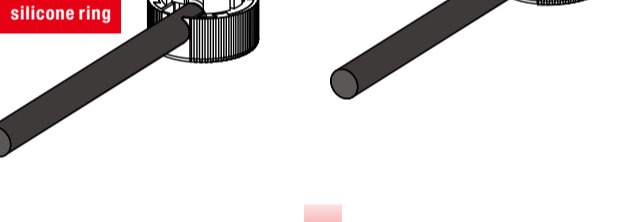

A-4

B-4

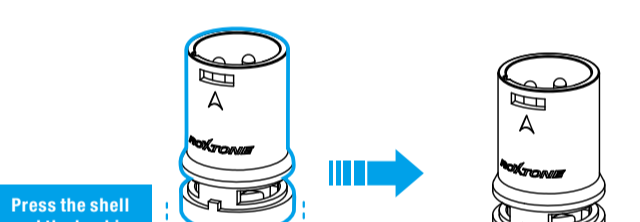
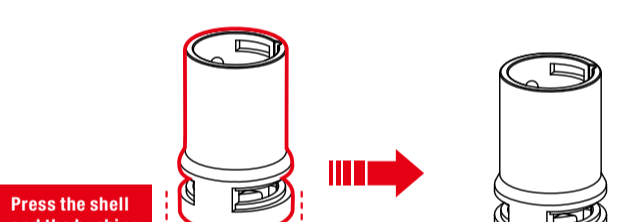

A-1

B-1

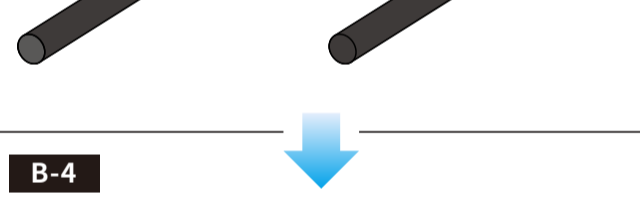
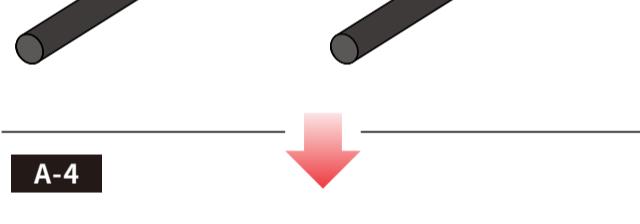

A-2

B-2

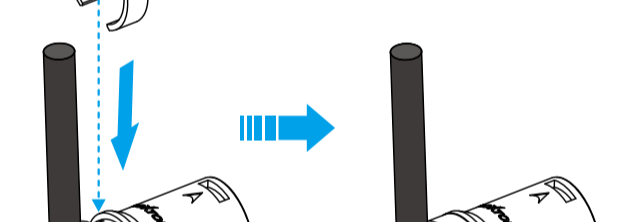
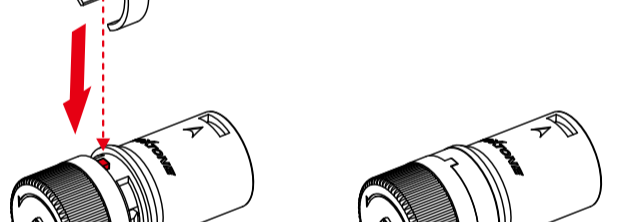

A-3

B-3



A-4

B-4

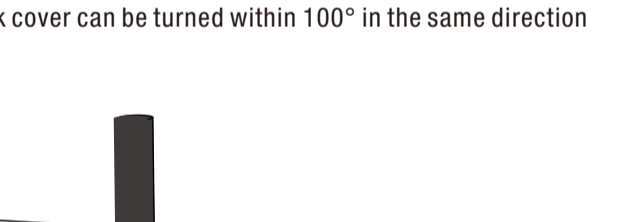
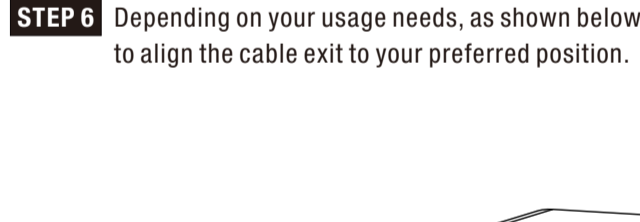

STEP 6 Depending on your usage needs, as shown below, the back cover can be turned within 100° in the same direction to align the cable exit to your preferred position.

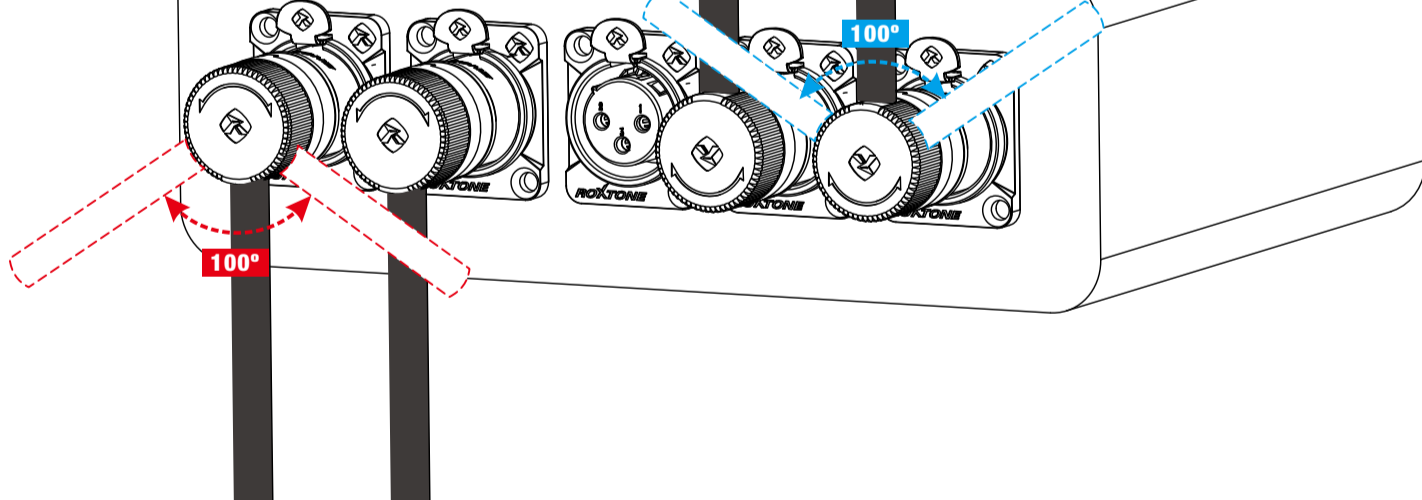

3. DISASSEMBLY INSTRUCTION

STEP 1 Remove the color ring.

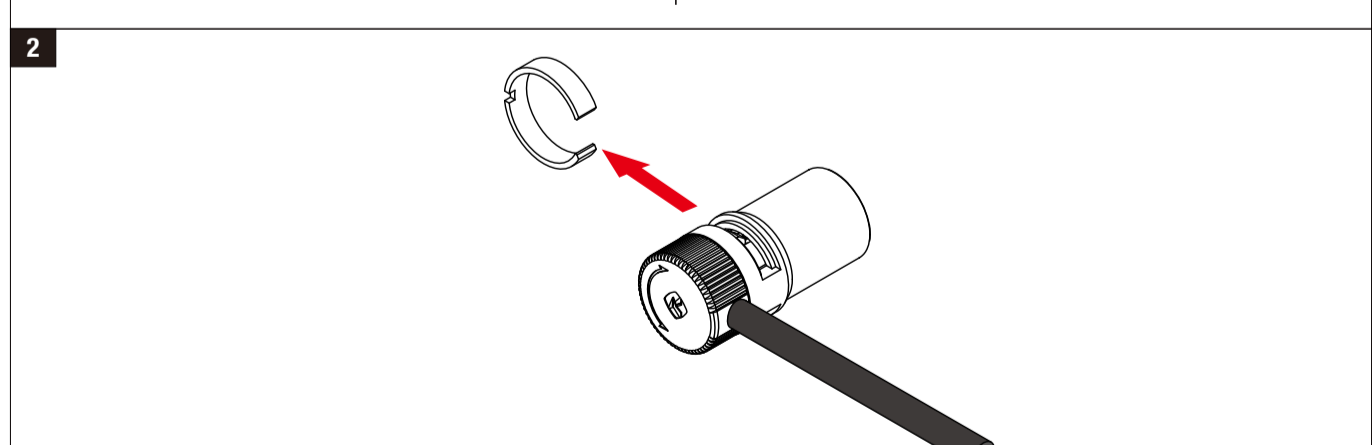
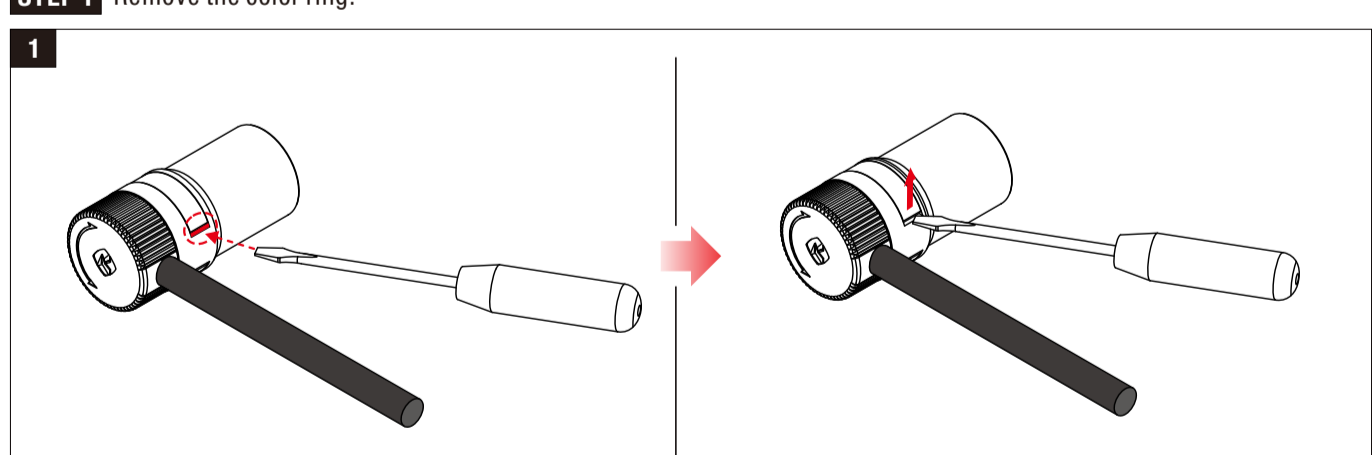

STEP 2 Remove the shell.

